

Semantic Knowledge Management: The Marriage Of Semantic Web And Knowledge Management

Edi

Department of Computer Science
STMIK TIME

Jalan Merbabu No. 32 AA-BB, Medan, North Sumatra 20212, Indonesia
Telp. : +62-81973173517, e-mail: edi_foe@yahoo.com

Abstract

Knowledge management (KM) has been known as important field in managing tacit and explicit knowledge in organization. The challenges that have been faced by KM such as information overload, inefficient keyword searching, etc need to be tackled by using semantic web technology. The purpose of this study is to analyze how the integration of KM and semantic web, which is so-called “semantic knowledge management” could be used to bridge the shifting from current Web 2.0 to future Web 3.0. Literature review is used as a research method in this paper. The research is limited to explicit knowledge being processed by machine.

Keyword: *Semantic knowledge management, semantic web, knowledge management*

1. Introduction

Since internet had been introduced, it has brought a tremendous effect to human life starting from Web 1.0 to Web 2.0. Web 1.0 which is always called as “Read-Only Web” [a], only allows users to read information that have been created by producers without any interaction between them. Web 2.0 appeared because of that shortcoming in web 1.0. Web 2.0 also called as “Read-Write Web” [a], allows users to interact such as writing comment toward information that have been posted by producers. Facebook, twitter, blogging are examples of Web 2.0.

Currently, we are living in information and knowledge society. There are billions information contained in internet. Web 2.0 used KM processes to create, capture, store, and share that information among users. However; the challenges that faced by KM such as “*information overload, inefficient keyword searching, heterogeneous information integration and geographically-distributed*

intranet problems” [2] need to be tackled by using semantic web technology [3] [4].

Semantic web technologies such as Resource Distribution Framework (RDF), SPARQL Protocol and RDF Query Language (SPARQL), and Web Ontology Language (OWL) bring machine closer to users and producers, in what we called as future “Web 3.0” [13].

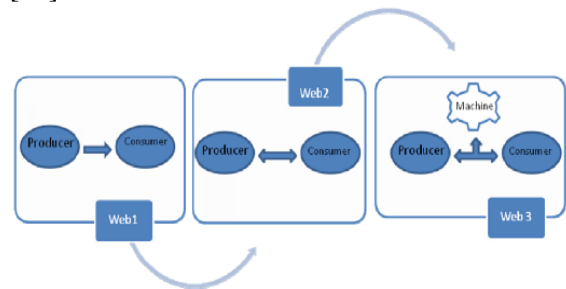

Figure 1. Web evolution [13]

There is no exact definition of Web 3.0, even from World Wide Web Consortium (W3C). According to [13], the principle of Web 3.0 is “*linking, integrating, and analyzing various data sources into new information streams*”. Web 3.0 is also called as “Read-Write-Execute Web” [a].

2. Methods

Literature review is chosen as a research method in this paper. In section 2, we will explain about knowledge management, semantic web, semantic knowledge management and their relationship with web 2.0 and web 3.0.

2.1 Knowledge Management

Knowledge has been regarded by as a power for organization to be competitive in this modern era. KM could be defined as managing tacit and explicit knowledge inside organization so that knowledge could be shared among workers. Tacit knowledge is about personal

experience whilst explicit knowledge deals with knowledge that gained from books.

Many scholars introduced stages of KM processes. It could be seen from [5][6][10][14]. Those papers contain four stages of KM in common: knowledge creation, knowledge storage/retrieval, knowledge transfer/sharing, and knowledge application.

Knowledge creation relates to creativity of individual/organization in developing new ideas or solutions whether through collaboration or individual process [10][11]. Knowledge storage/retrieval is about how to maintain knowledge that has been acquired and how to retrieve knowledge that has been stored. IT plays role in realizing knowledge storage/retrieval. Knowledge transfer/sharing relates to spreading knowledge among individuals/workers in organization. Knowledge application relates to application/system that uses knowledge to solve problems, such as decision support system, expert system.

There are four basic patterns in creating knowledge according to [7] namely Socialization, Externalization, Combination, Internalization, which is abbreviated as SECI model. Socialization regards to transferring tacit to tacit knowledge through shared experience or ideas. Externalization is about conversion of tacit to explicit knowledge through written documents, concepts, and images. Combination regards to combine explicit knowledge with another explicit knowledge so it comes to new and update explicit knowledge. Internalization relates to conversion of explicit to tacit knowledge through learning-by-doing, practice from what has been learned/read from books or written documents. SECI model is also called as the “spiral of knowledge” [7] because it starts from Socialization, goes to Externalization, continue to Combination, then Internalization, after that it goes back to Socialization, and so on.

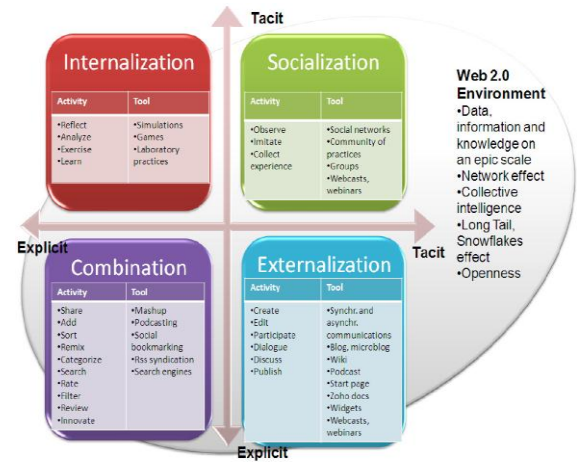

Figure 2. SECI model for knowledge creation in Web 2.0 environment [11]

Web 2.0 tools support knowledge creation, it could be seen from figure 2. The tools that support Socialization are social networks, community of practices, groups, webcasts and webinars. For supporting conversion of tacit to explicit knowledge (Externalization), the tools that could be used like synchronous and asynchronous communications, blog and microblog, wiki, podcast, start page, zoho docs, widgets, webcasts and webinars. Mashup, podcasting, social bookmarking, RSS syndication, and search engines could be used to support Combination process. The process of Internalization could be supported by tools like simulations, games, and laboratory practices.

2.2 Semantic Web

The term “Semantic Web” was introduced by Tim Berners-Lee in 1998 [8]. According to [15], “*Semantic web is not a separate web but an extension of the current one, in which information is given well-defined meaning, better enabling computers and people to work in cooperation*”. Semantic web gives machine the ability to understand the meaning of words. For example, in current web 2.0 search engine, when we type keyword “budget hotel”, the search engine works based on keyword match, it means that the result of searches will come out with webpages that contain either budget or hotel. Contrast with that, in future web 3.0 search engine, the search engine works based on semantic/meaning, it means search engine will understand that the user would like to find the hotel that in the lowest cost (cheap hotel).

The layer cake framework of semantic web describes the hierarchy of semantic web technologies development. There are seven

layers started from lower to higher level: Unicode and namespace, XML, RDF(S), ontology, logic, proof, and trust as described in figure 3.

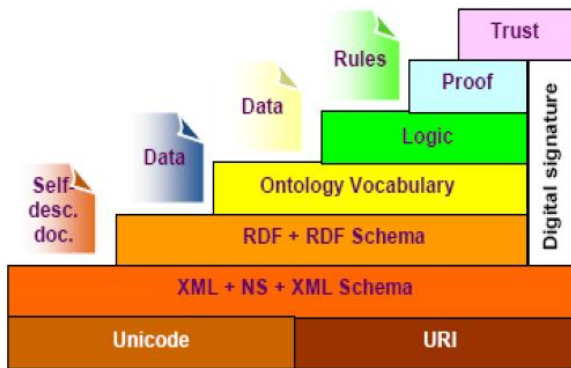

Figure 3. Layer cake of semantic web [1]

Two important technologies for developing semantic web are XML and RDF [15]. XML allows everyone to put tags on the web pages, while RDF is functioned to understand the meaning of the sentence, in which it consists of subject, verb, and object (always called as triple). The triple could be written using XML tags [15]. For instance, the XML-based RDF syntax below shows that Edi is a Lecturer at STMIK TIME.

```
<?xml version="1.0"?>
<rdf:RDF
xmlns:rdf="http://www.w3.org/1999/02/22-rdf-syntax-ns#"
xmlns:id="http://www.stmik-time.ac.id/Department#">
<rdf:Description
rdf:about="http://www.stmik-time.ac.id/id/ComputerScience#">
  <id :name>Edi</id:name>
  <id:position>Lecturer</id:position>
</rdf:Description>
</rdf:RDF>
```

Many semantic web products have been released. The ReadWriteWeb chose top ten semantic web products of 2010 [b], including GetGlue, Flipboard, Hunch, and Aapture.

2.3 Semantic Knowledge Management

According to [12], “semantic knowledge management is a set of practices that maintains data with its metadata in a machine readable format”. In a nutshell, semantic knowledge management could be defined as semantic web that uses KM processes in realizing Web 3.0.

There are six stages in semantic knowledge management according to [8]. Those are representation, interconnection, reasoning, retrieving, validation, and integration.

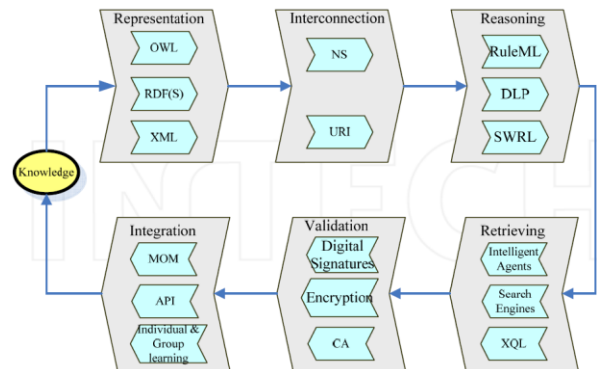

Figure 4. Stages in semantic knowledge management [8]

Figure 4 describes the role of semantic web in each phase of KM, such as semantic web technologies like OWL, RDF(S), and XML are used to represent knowledge in machine-readable format.

[9] propose semantic knowledge management for grid applications, as shown in figure 5. Figure 5 shows that the semantic web technologies are used to support knowledge acquisition, modelling, representation, publishing, storage, and reuse [9].

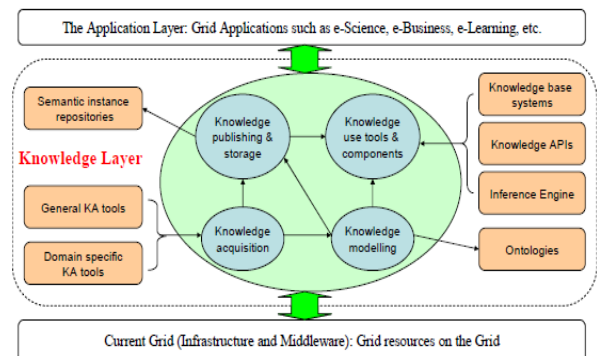

Figure 5. The semantic web based approach to knowledge management [9]

Many researches have been done regarding implementation of semantic knowledge management for Web 3.0. [12] introduced Semantic Knowledge Management Tool (SKMT) as a platform to search, analyze, and manage enterprise content. [16] used semantic knowledge management for distributing knowledge between biological researchers.

3. DISCUSSIONS

Literature review that used in this paper comes from journals, books, conferences, and websites. Evaluation of literature review is based upon on different phases of semantic knowledge management that have been proposed by researchers. The result of evaluation could be seen in section 4.

4. RESULTS

The purposed phases of semantic knowledge management may be different from one research to others as shown by [8] and [9]. This is because of implementation in different field which means that phases of semantic knowledge management in one field may be can not be implemented in another field.

Eventhough we are still leaving in web 2.0 and the development of web 3.0 is still in progress, semantic knowledge management has proved its ability to support web 3.0. It could been seen from researches that use semantic knowledge management in diverse field such as grid applications, biological research, and education.

5. REFERENCES

- [1] A. Medic and A. Golubovic, "Making Secure Semantic Web", *Universal Journal of Computer Science and Engineering Technology*, vol. 1, no. 2, pp. 99-104, 2010.
- [2] D. Fensel, C. Bussler, Y. Ding, V. Kartseva, M. Klein, M. Korotkiy, B. Omelayenko, and R. Siebes, "Semantic Web Application Areas", *In Proc. 7th International Workshop on Applications of Natural Language to Information Systems (NLDB 2002)*, 2002.
- [3] D. Fensel, *Ontologies: Silver Bullet for Knowledge Management and Electronic Commerce*, Springer-Verlag, Berlin, 2001.
- [4] D. Fensel, J. Hendler, H. Lieberman, and W. Wahlster, *Semantic Web Technology*, MIT Press, Boston, 2002.
- [5] F. Bouthillier and K. Shearer, "Understanding knowledge management and information management: the need for an empirical perspective", *Information Research Journal*, vol. 8, no. 1, 2002.
- [6] H. Lai and T. H. Chu, "Knowledge Management: A Review of Theoretical Frameworks and Industrial Cases", *In Proceedings of the 33rd Hawaii International Conference on System Science*, 2000, IEEE.
- [7] I. Nonaka. "The Knowledge-Creating Company". *Harvard Business Review*, pp. 162-171, July-August 2007.
- [8] L. Chao, Y. Zhang, and C. Xing, *The Semantic Web-Based Collaborative Knowledge Management*, New Research on Knowledge Management Technology, Dr. Huei Tse Hou (Ed.), InTech, 2012.
- [9] L. Chen, N. R. Shadbolt, and C. A. Goble, "A Semantic Web Based Approach to Knowledge Management for Grid Applications", *IEEE Transactions on Knowledge and Data Engineering*, pp. 1-14, 2006
- [10] M. Alavi and D. Leidner, "Review: Knowledge Management and Knowledge Management System: Conceptual Foundations and Research Issues", *MIS Quartely*, vol. 25, no. 1, pp. 107-136, 2001.
- [11] M. Ivanova and T. Ivanova, "Web 2.0 and Web 3.0 Environments: Possibilities for Authoring and Knowledge Representation", *Revista de Informatica Sociala*, vol. 7, no. 12, pp. 7-21, 2009.
- [12] M. Kalender and J. Dang, "SKMT: A Semantic Knowledge Management Tool for Content Tagging, Search and Management", *Eighth International Conference on Semantics, Knowledge and Grids*, pp. 112-119, 2012.
- [13] M. M. I. Pattal, L. Yuan, and Z. Jianqiu, "Web 3.0: A real personal Web!", *3rd International Conference on Next Generation Mobile Applications, Services and Technologies*, 2009.
- [14] M. Parikh, "Knowledge Management Framework for High Tech Research and Development", *Engineering*

Management Journal, vol. 13, no. 3,
pp. 27-34, 2001.

[15] T. B. Lee, J. Hendler, and O. Lassila.
“The Semantic Web”. *Scientific
American*, vol. 5, pp. 34-43, 2001.

[16] T. H. Huang and H. C. Wang,
“Semantic-based Knowledge
Management for Biological Research”,
Asia Pacific Management Review, vol.
17, no. 3, pp. 247-261, 2012.

Websites:

- [a] T. Fleerackers, Flat World Business,
<http://flatworldbusiness.wordpress.com/flat-education/previously/web-1-0-vs-web-2-0-vs-web-3-0-a-bird-eye-on-the-definition/>
- [b] R. MacManus, Top 10 Semantic Web
Products of 2010,
http://readwrite.com/2010/12/29/top_10_semantic_web_products_of_2010#awesm=~orH5gMdehetB4L